

Making music can be very relaxing but it is also demanding, especially when performing at a high level. You can play comfortably and relaxed now, with an ergonomically adapted instrument.

The ETUDE 3 Thumb Rest and other Kooiman products help you to easily realize this adaptation. Using a traditional thumb rest, the instrument rests at the very end of the thumb. This places a heavy load on the thumb.

The Kooiman ETUDE 3 Thumb Rest has the instrument resting between the two parts of the thumb. The illustrations alongside clearly show the difference.

The ETUDE 3 strongly reduces the required muscle power. As the hand can be much more relaxed, the fingers gain additional freedom of movement. The third and fourth fingers can reach the lower part of the mechanism more easily.

Compared to a traditional thumb rest, the ETUDE 3 Thumb Rest is located higher up the instrument. As a result, the thumb regains its natural position rather than being pushed downward. The lightly curved thumb makes sure the instrument is actively supported by the player. This may require some getting used to. Please note that the thumb should always be in full contact with the thumb rest case.

The height of the thumb rest can be adjusted in three ways:

1. The position of the mounting plate can be changed, using either the lower or the higher pair of holes.
2. The case can be slid further down with the ratchet system.
3. The hook can be adjusted up (for larger hands) and down (for smaller hands and thinner fingers) with the screw at the bottom of the case (4)

ASSEMBLY

- Remove the current thumb rest.
- Use the two screws (2) that come with the ETUDE 3 to attach the mounting plate (1) with its middle pair of holes to the instrument (see illustration). Should the existing holes in the instrument be too narrow or too shallow, you can expand them with a 1.7mm drill bit. Leave this

drilling to your technician if you're not sure you can manage this without piercing the wall or otherwise damaging the instrument.

- Slide the case (3) over the mounting plate from the top down. (Sliding it over the plate from the bottom up will damage it!). You will hear some clicks as you go. Usually the thumb rest will be at the desired height at the third or fourth click.

IMPORTANT

To fully enjoy the ETUDE 3 Thumb Rest please read this manual carefully. It is as important to take ample time to get used to the new position of your thumb.

ADDITIONAL INFORMATION

For additional information please visit our website at www.tonkooiman.com

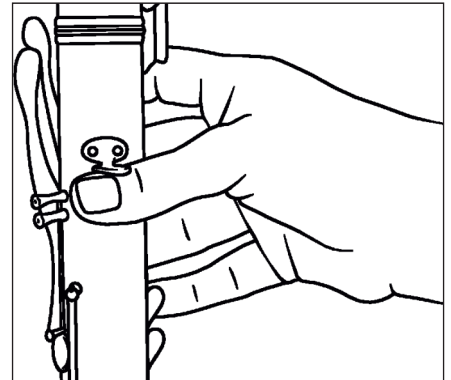

Traditional thumb rest

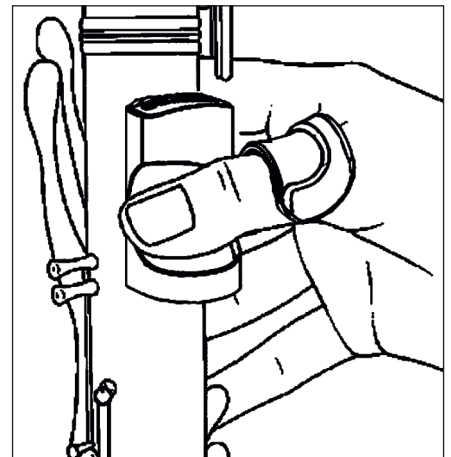

Etude 3

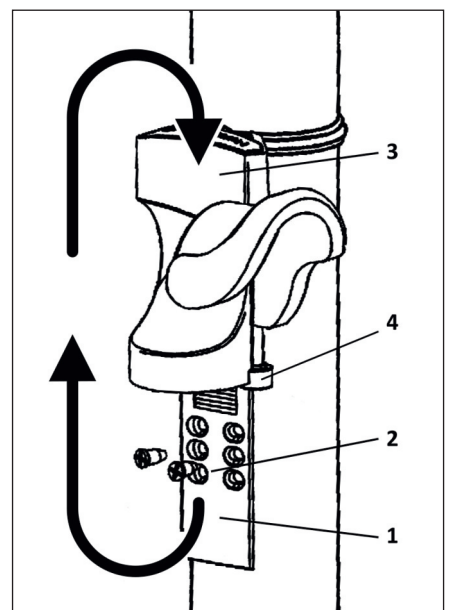

Assembly